

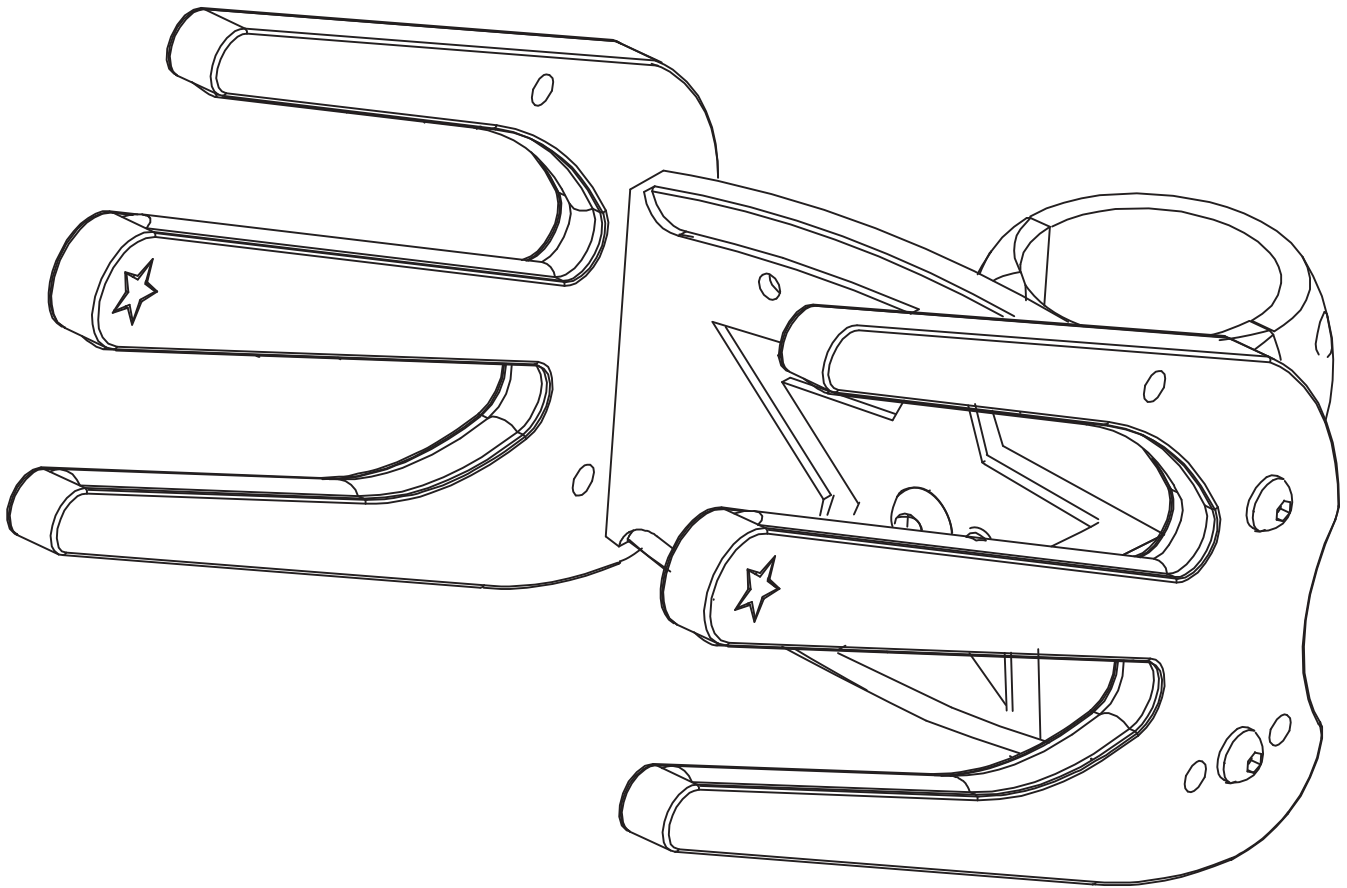

# INDY WAKEBOARD RACK



## INSTALLATION GUIDE

---

## EXPLODED VIEW OF THE INDY WAKEBOARD RACK

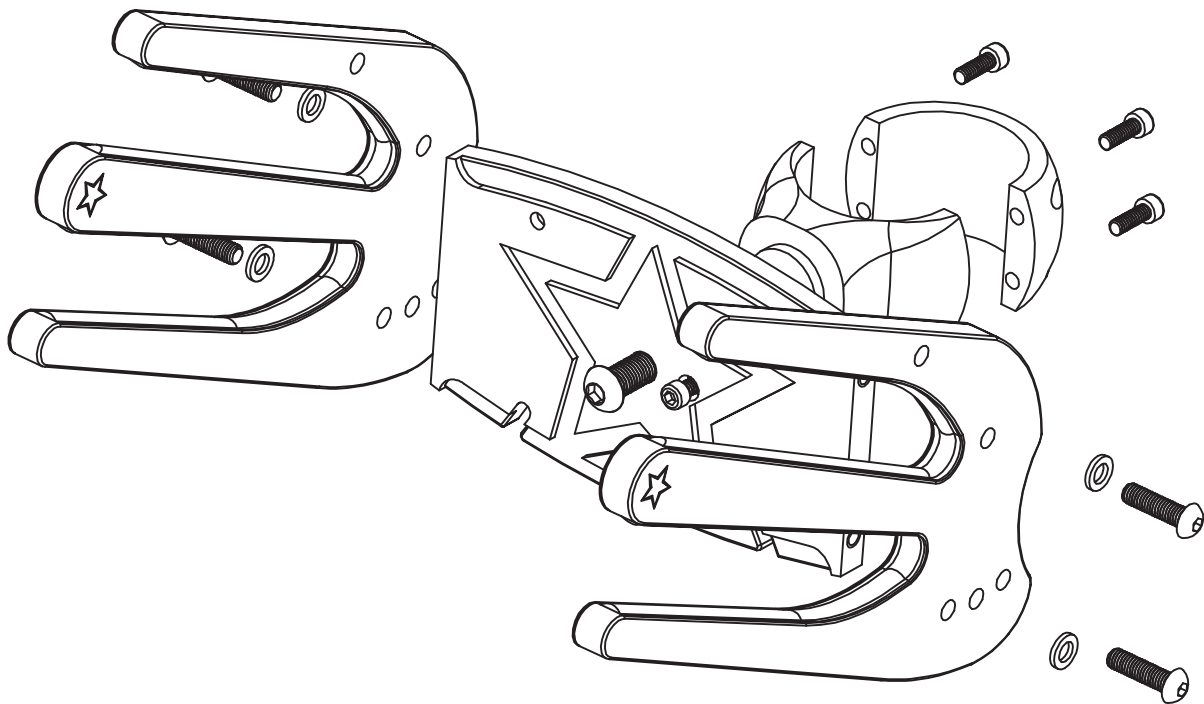

### STEP 1:

#### Unpack and check the contents of the box

Check the parts list and the Instruction Guide correspond with the product you purchased  
Ensure you have the correct tools to complete the Installation.  
Ensure you have the skills to complete the installation

Please Read all Instructions prior to installation

If you are NOT sure of any part of the guide or you have any questions  
Please contact the supplier or Indy Wakeboard Towers

**Email: [indywakeboardtowers@gmail.com](mailto:indywakeboardtowers@gmail.com)**

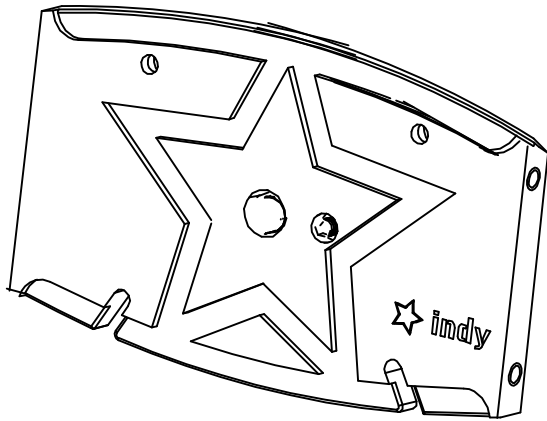

1 x Base plate

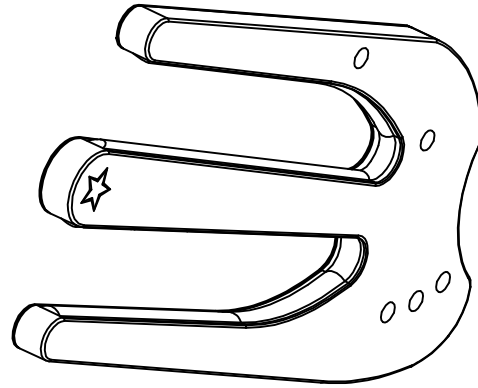

2 x rack fingers

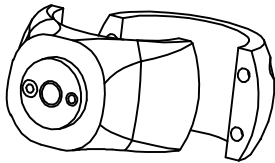

1 x Clamp (plus rubber inserts)

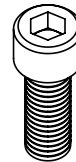

4 x M6 long bolts for clamp

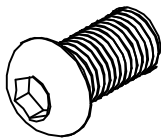

1 x M12 centre base bolt



1 x M6 Short bolt

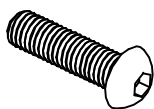

4 x M8 long bolts for fingers



4 x small white plastic washers

## Step 2: Attaching the wakeboard rack fingers to base plate.

**NOTE:** The wakeboard rack fingers you will notice have three small holes grouped together. This is the bottom of the wakeboard rack finger.

**NOTE:** The base plate has the star Indy logo stamped in it. Ensure you can read this when installing the fingers.

**NOTE:** The wakeboard rack fingers attach to the side of the base plate.

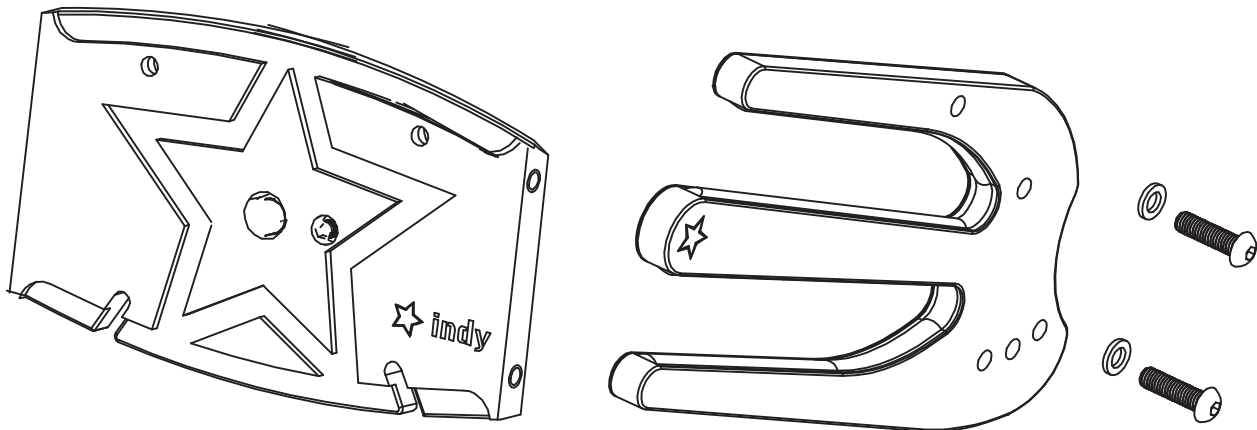

(A) Select one of the holes in the group of three holes. Insert a bolt with a plastic washer through it. The upper smaller hole will line up with the top hole on the side of the base plate. The assembled finger should look like picture below.

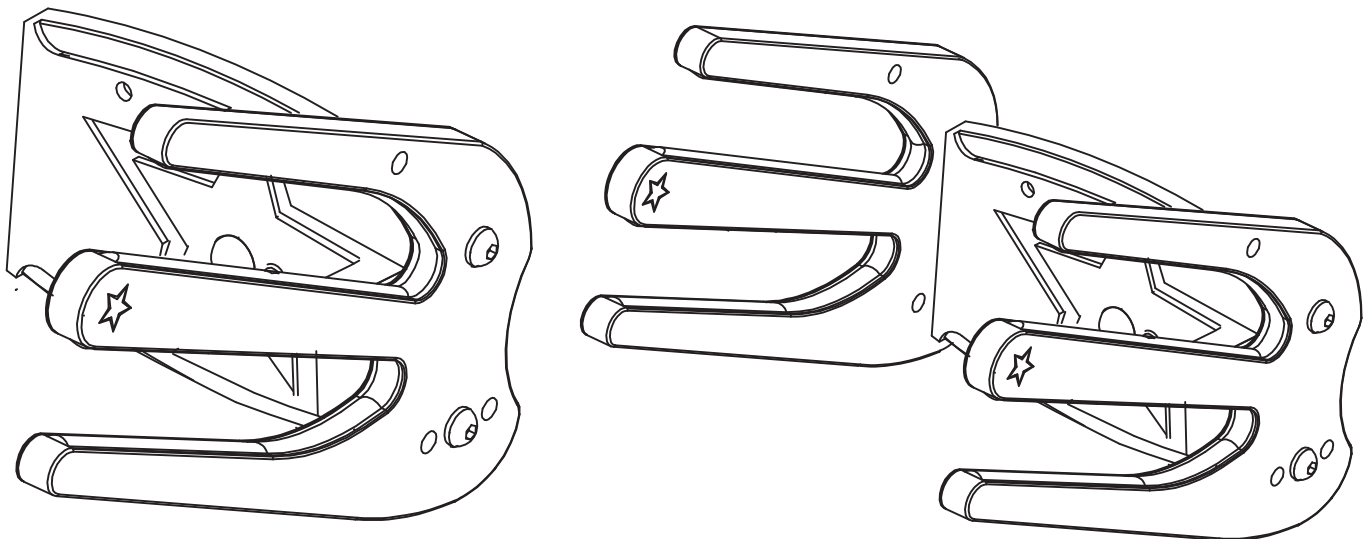

(B) Repeat process with the other wakeboard rack finger.

**NOTE:** the position of the Logo engraved star and the direction the fingers are facing.

## INSTALLATION GUIDE

### STEP3: ASSEMBLE THE BALL CLAMP.

(A) The ball clamp has two C shape sections. Line up the holes insert the 4 x long M6 bolts. Check that the half C section is flush around the edge with the other half. If NOT flush remove and rotate the C section and re attach.

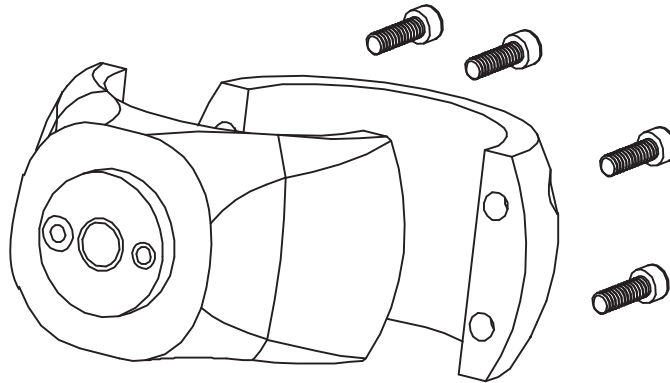

### STEP4: ATTACHING THE BASE PLATE TO THE CLAMP.

(A) The back of the base plate has a counter sunk circle with a hole in the middle. The clamp has a raised circular area with a threaded hole in the center. Insert the clamp into the base plate.

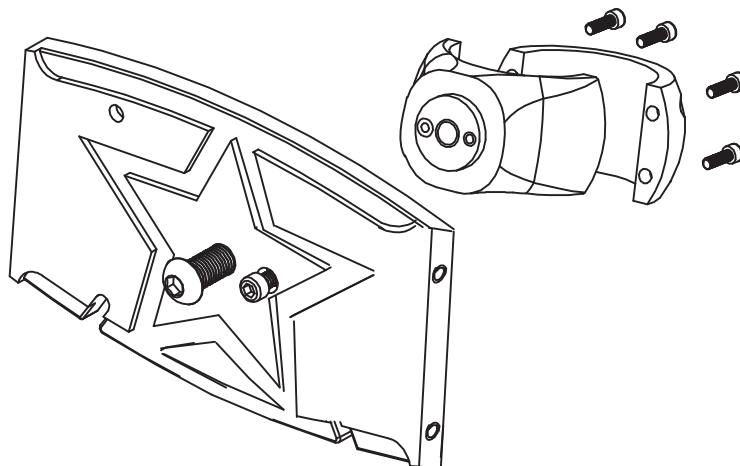

(B) Put the large dome shape M12 bolt through the front of the base plate into the threaded hole in the clamp. You can now rotate the base plate. Tighten the centre bolt, insert the small M6 bolt in the threaded hole from the front of the base plate. It will lock the rack into position to stop the base from rotating.

## INSTALLATION GUIDE

## **STEP5: ATTACHING WAKEBOARD RACK TO TOWER LEG.**

**NOTE:** The clamp size is 2.5inch you will use the thin rubber collar for an INDY tower. The outer lip of the rubber insert will fit nice around the shape of the ball clamp.

(A) Place the rubber collar around the tower tube at the height you require. Put the half C section of the clamp on top of the rubber collar, face logo into the boat. Now attach the other half of the ball clamp.

**NOTE:** Check the edges of the clamp joint are flush, if not turn the C section around. The bungee cord goes over your boards and lock into the cut outs on the base provided.

**UPGRADE WITH SWING RACK ADAPTORS** - check out [www.indywakeboardtowers.com](http://www.indywakeboardtowers.com)

### **WARNING:**

Remove your boards when towing the boat behind your vehicle.  
Remove base and fingers from clamp whilst towing behind vehicle  
Swing the fingers to face inside the boat outline when tower behind a vehicle.  
Check that your rack is firm and tight and functioning correctly before use.  
Care and maintain your racks. Clean with soapy water and rinse off and dry.  
Use a marine clear protection spray on bolts for best maintenance.

### **WARRANTY**

Indy warrants the product (not including other 3rd party accessories) against manufactures defects.

To claim you must contact Indy or its Distributor. The product/part is to be sent to the Distributor for inspection where it will either be repaired or replaced. (unless otherwise agreed in writing)  
The customer is liable for costs associated in shipping the product/part to Indy.

Indy is not responsible for personal injury or damage to the boat caused by the use wakeboard rack or any transport charges or cost of installation or removal of the wakeboard rack.  
Indy is not liability for direct or indirect or consequential damages resulting from delay or improper installation.

Warranty does NOT cover anodised, polished, powder coated surfaces as well as any hardware corrosion, rubber inserts or bungee cord. They are specifically excluded as their care and use can not be controlled by Indy.

No dealer, retailer or manufacturer is the agent of James G Pty Ltd and may not assume any liability in connection with this warranty. This warranty is in lieu of all.

## **INSTALLATION GUIDE**

---