

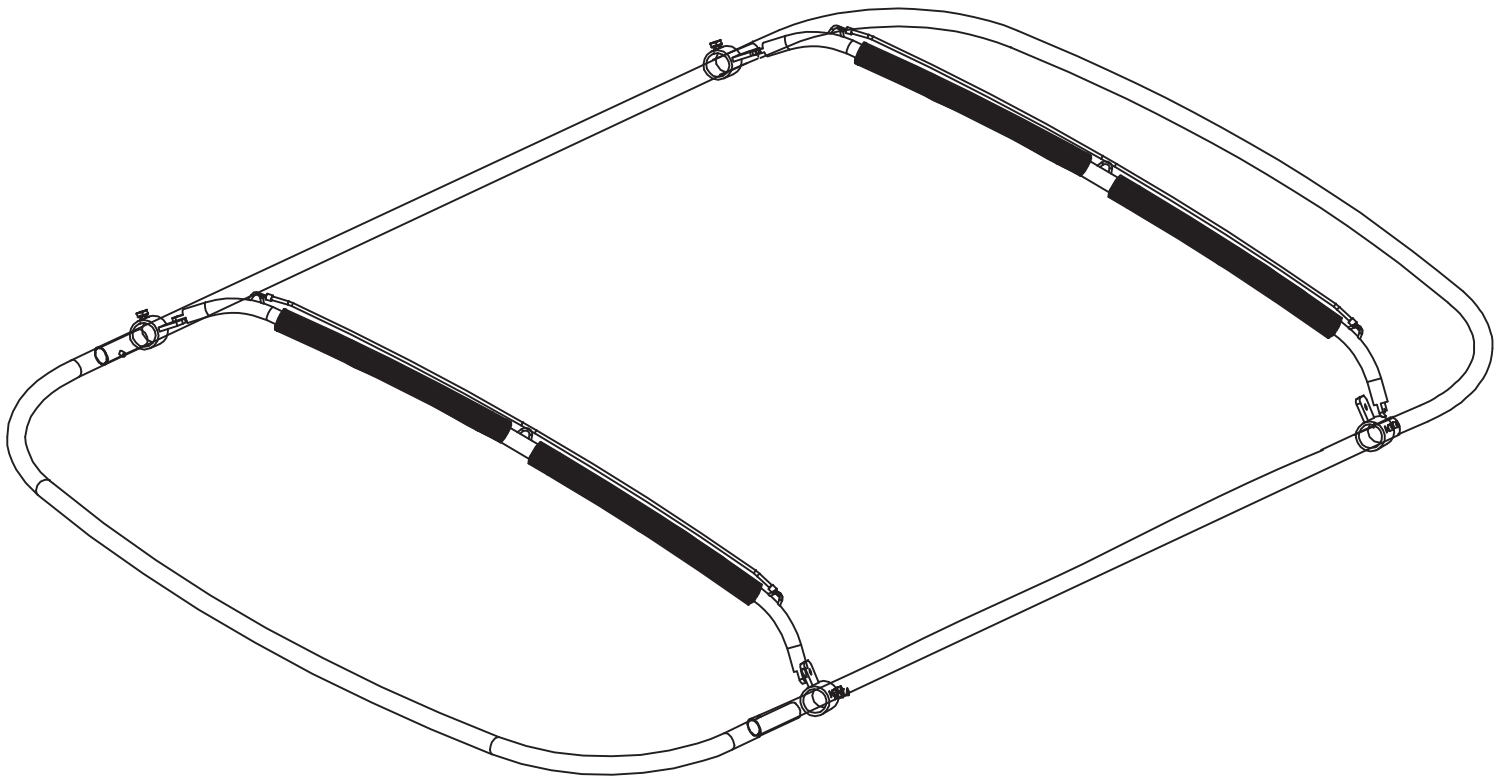

INDY WAKEBOARD TOWER BIMINI TOP RACKS



INSTALLATION GUIDE

EXPLODED VIEW OF THE INDY WAKEBOARD TOWER BIMINI RACKS

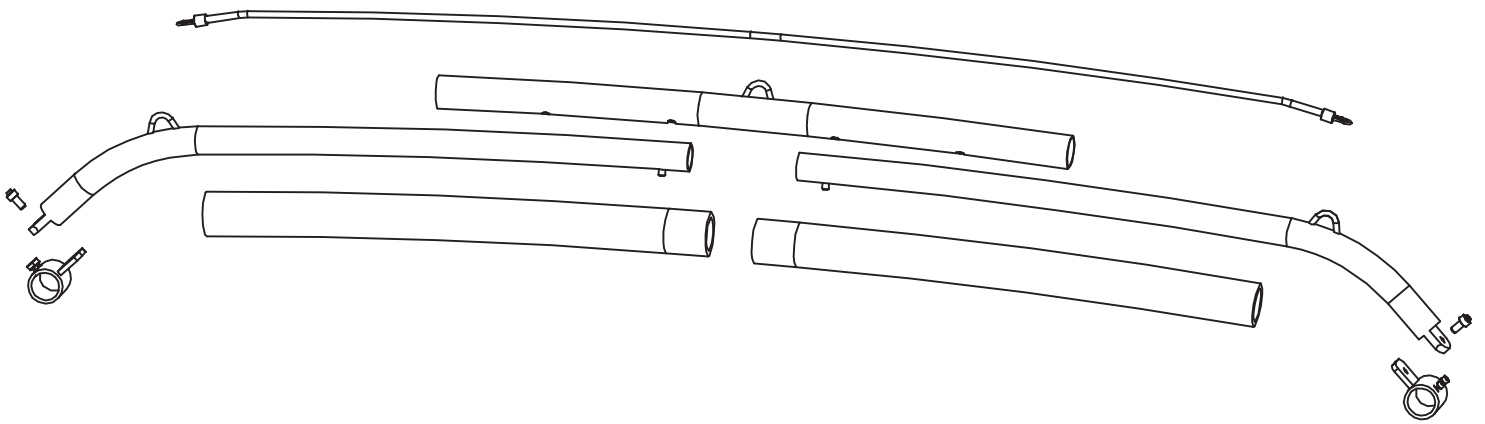

STEP 1:

Unpack and check the contents of the box

Check the parts list and the Instruction Guide correspond with the product you purchased
Ensure you have the correct tools to complete the Installation.
Ensure you have the skills to complete the installation.

Please Read all Instrustion prior to installation

If you are NOT sure of any part of the guide or you have any questions
Please contact the supplier or Indy Wakeboard Towers

Email: indywakeboardtowers@gmail.com
www.indywakeboardtowers.com

INSTALLATION GUIDE



4 x M6 Bolts

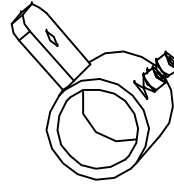

4 x Stainless Steel tube fittings

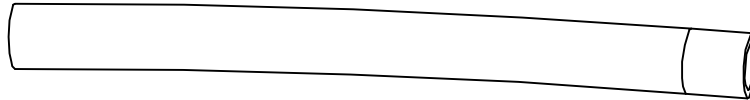

4 x Foam tubes with Sunbrella Material velcro covers

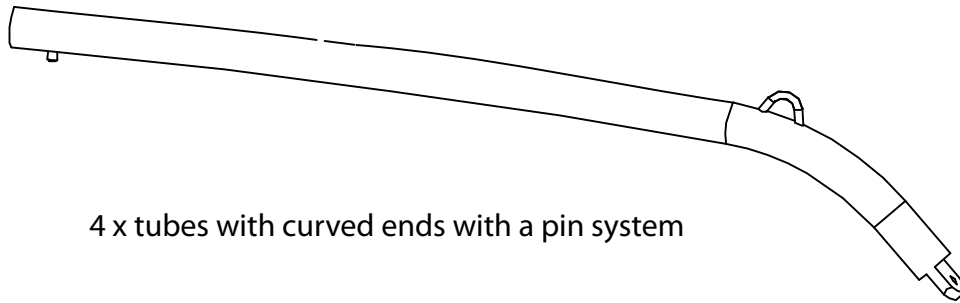

4 x tubes with curved ends with a pin system

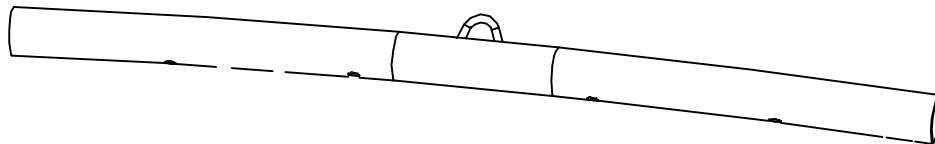

2 x Centre tubes with pre drilled holes and welded hook

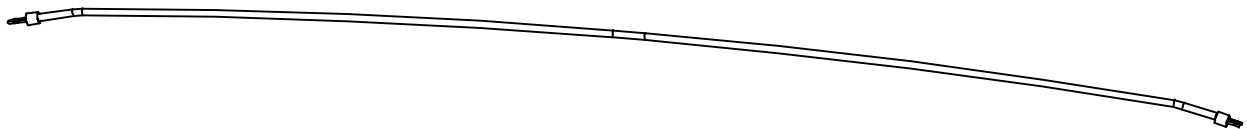

2 x black lengths of bungee cord + 4 plastic snap on hooks.

INSTALLATION GUIDE

Step 2: Assemble the wakeboard tower bimini racks

Spread your parts out on the floor or table. Follow the picture flow chart below.

(a) Insert the curved tube with pin system into the foam tube. Push the tube completely onto the stainless steel tube up against the hook, to expose the pin in the tube.

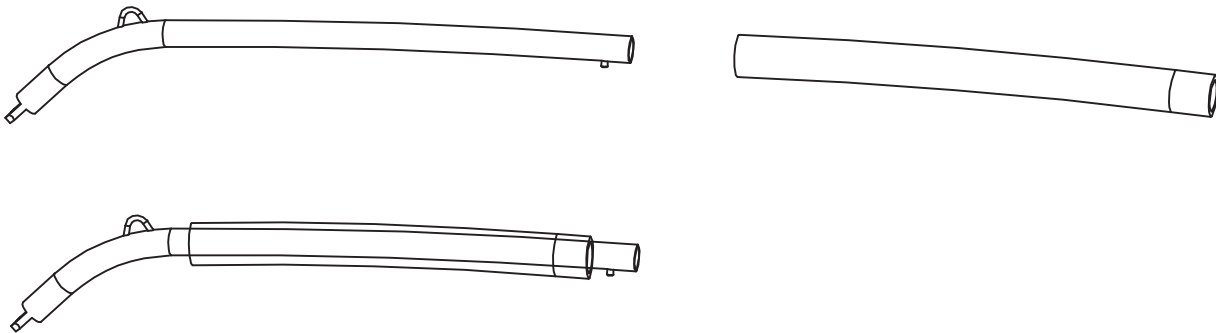

(b) Find the centre piece of the rack with the pre drilled holes. Now insert the tube with the pin into the centre piece. You need to push back the foam section, press in the pin and insert into the centre piece. Slide the tubes together until the pin slots into the open hole.

Note: Measure the width of your Indy wakeboard tower bimini top. For the 1580mm wide top. Insert into first hole. If you have the small 1350mm wide Indy Bimini Top insert into the second hole.

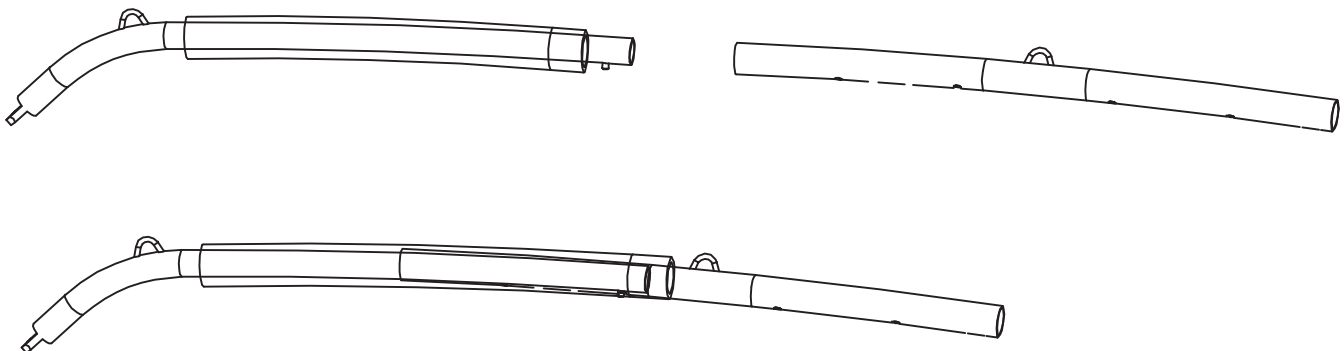

(c) Repeat this process for the opposite side and with the foam tubing, material cover and bent tube for the Bimini top racks.

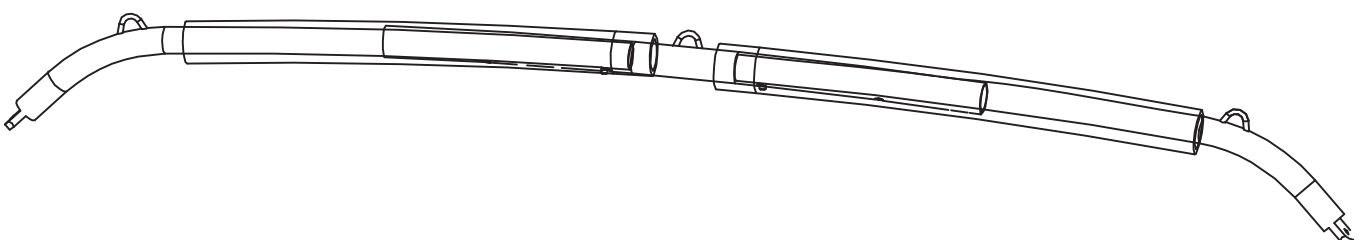

INSTALLATION GUIDE

Step 3: Attaching the bimini top racks to your Indy Wakeboard Tower Bimini Top

- (a) First remove the Sunbrella Material cover from you Indy Wakeboard Tower Bimini top frame.
- (b) Detach the front bar of the frame and insert the small SS fitting onto the frame. Note the fitting has a small threaded hole. Leave the SS fitting loose at first so you can slide the fitting into the desired position and then lock into position with the small grub screws.
- (c) Once you have the racks in position you can lock tight the grub screws and screws into position.

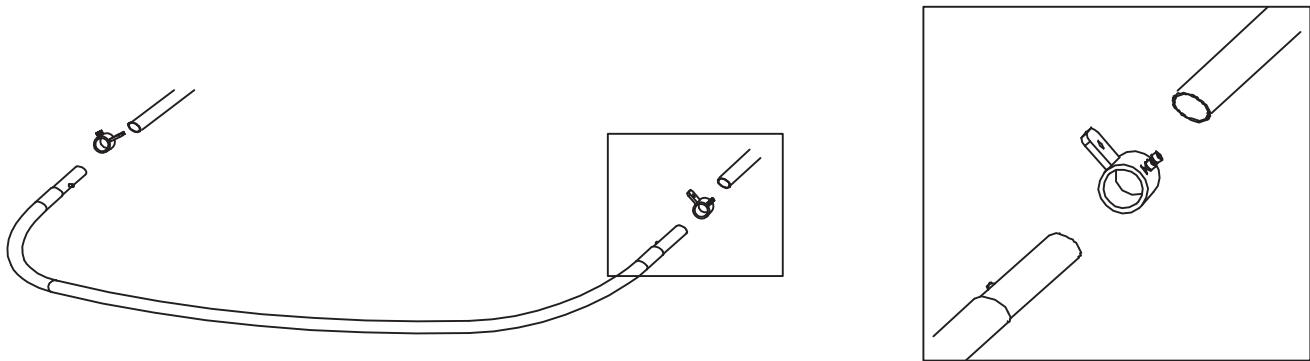

(d) Repeat the above steps at the rear of the wakeboard tower bimini top by removing the rear curved bar. Place fittings in the area where the frame is exposed and not blocked by the material.

(e) Now you can use the small M6 bolt and attach the rack to the SS fitting you have on the bimini frame Attach both side.

(f) Now replace the material sunbrella cover and adjust the racks to the desired position and lock into position with the small grub screws. recommended to use lock tight when you are happy with the position.

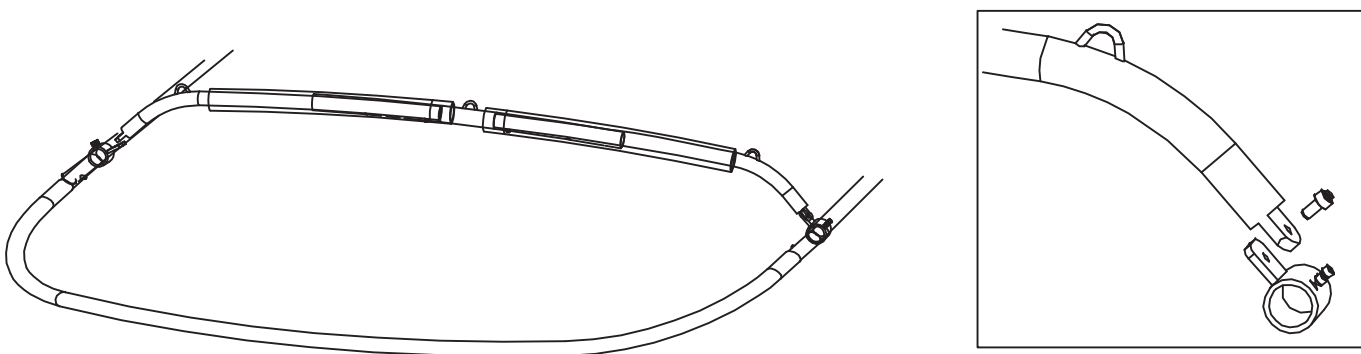

INSTALLATION GUIDE

Step 4: Attaching the bungee cord to the Indy wakeboard tower bimini top racks

(a) You are supplied with two lengths of black bungee cord. After you have install the bimini racks to the width require you can adjust and cut the bungee cord to the length you require.

Note allow for kneeboard thickness, it is best to place the racks onto the bimini first. sotre some of you watersports equipment and then adjust to the length required.

(b) The square insert picture below show you how you thread the bungee cord through the centre hook that is welded in the centre of the racks.

(c) You will notice that the small plastic hooks have a cap you thread the bungee cord throughfirst and then insert into the hook area and then snap together. If you have the wrong length you can take the hook apart and cut to the correct length required.

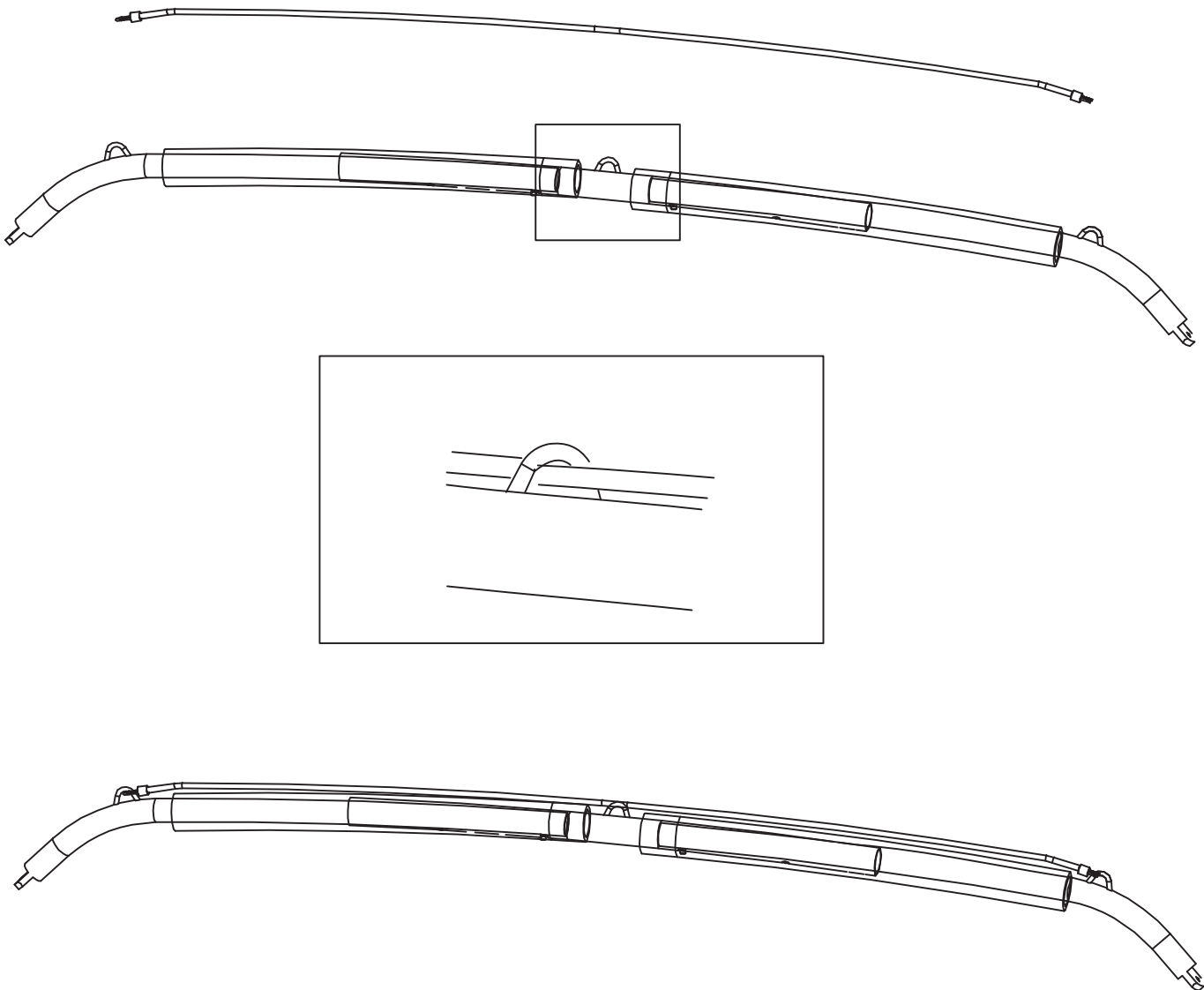

INSTALLATION GUIDE

CARE AND MAINTENANCE

Be sure to check and tighten all fasteners and connections prior to every use
Be cautious when you attach the hook and ensure they are secure
Ensure that the water sports equipment is held in a nice firm position
Do not travel at high speeds whilst you have watersports equipment attached to racks
Use soap and water to clean your tower.
Always rinse and wipe down tower after contact with salt (brackish) water.
The material is 304 stainless steel you will need to clean and polish the tubes and fittings to ensure not surface rust appears. If left unattended surface rust will appear.
You can spray a marine clear application over your fittings to help protect them from the environment
Also lock tight your small grub screws and screws.

WARRANTY

Indy warrants the product (not including other 3rd party accessories) against manufactures defects.

To claim you must contact Indy or its Distributor. The product/part is to be sent to the Distributor for inspection where it will either be repaired or replaced. (unless otherwise agreed in writing)
The customer is liable for costs associated in shipping the product/part to Indy.

Indy is not responsible for personal injury or damage to the boat caused by the use of the product or any transport charges or cost of installation or removal of the product. Indy is not liability for direct or indirect or consequential damages resulting from delay or improper installation.

Warranty does not cover anodised, polished, powder coated surfaces as well as any hardware corrosion, rust, they are specifically excluded as their care and use can not be controlled by Indy.

Indy Wakeboard Towers
www.indywakeboardtowers.com

INSTALLATION GUIDE
